



F#1

Single Action

External Mix Airbrush

OPERATING INSTRUCTIONS AND REPLACEMENT PARTS

WARNING: Spray materials may be harmful if inhaled or allowed to come into contact with the skin or eyes. Consult the product label and Material Safety Data Sheet supplied for the spray material. Follow all safety precautions.
CAUTION: Well Ventilated Area Required to remove fumes, dust or overspray. Secure airhose to Airbrush with V-62 Wrench for safety and to prevent air leaks.
Maximum Air Pressure 75 P.S.I.



INTRODUCTION:

F#1 Airbrush is the simplest in design with the least number of parts, supplying independent control of air and color. Ideal for use by students and hobbyists, also for touch up and decorating.

OPERATING INSTRUCTIONS: Pressures:

- 10 lbs. for stipple and granulated effects.
 - 20 lbs. for light consistency water colors, inks & dyes.
 - 30 lbs. for medium fluids, reduced lacquers, varnishes, paints or ceramic glaze. F#1 Airbrush will not handle heavy fluids.
1. Attach hose to air supply and allow to blow a few seconds at full pressure. Shut off before attaching to Airbrush. This procedure will remove dirt from airline and hose.
 2. Attach AC-20 (1/8"-1/4"-40) Coupling to the Airbrush.
 3. Attach Color Cup or Bottle to FN-1 Needle by exerting a firm twisting motion to fit taper tube securely into tapered Needle inlet. To remove Color Cup from FN-1 Needle, exert a backwards twisting and pulling motion.
 4. Fill Color Cup or Bottle 1/2 to 3/4 full. Use eyedropper or brush for adding small amounts of color to cup. When using Color Bottle, vent hole must be kept open.
 5. To Spray: Hold Airbrush like a pencil, comfortably between thumb and forefinger using middle finger as a guide and support.
 6. Like writing, hold forefinger easily on H-155 Finger Button-press to open air valve.
 7. Regulate volume of color and size of spray by rotating FT-1 Tip clockwise to increase, and counterclockwise to decrease, flow of color.
 8. Stipple adjustment: For a very coarse stipple, loosen and slide back FN-1 Needle. Increase the volume of fluid until a free flow of color is achieved. Regulate air pressure and fluid feed for a variety of stipple effects.

CARE AND CLEANING:

1. Pour any remaining color back into its original container.
2. Wipe Color Cup or Bottle clean, using a cloth moistened with proper solvent.
3. Hold airbrush at a downward angle and put a few drops of solvent through the F-1 Color Adjusting Part Assembly. To flush out the remaining color in the F-1 Color Adjusting Part Assembly, apply pressure to the H-155 Finger Button.
4. Apply a tiny dab of petroleum jelly to the F-1 Color Adjusting Part Assembly and HC-1 Aircap threads every two or three months to prevent color build up and consequent freezing of the Color Adjusting Part Assembly and Aircap.

HOW TO OPEN CLOGGED FLUID PASSAGES:

1. Agitate color in Bottle Assembly by placing finger momentarily over HC-1 Aircap while air is passing through the Airbrush. (This will blow color back into bottle thus opening clogged fluid passages.) **Do not do this with a cup as color may blow out.**
2. Should F-1 Color Adjusting Part Assembly become clogged, loosen H-153 Set Screw, unscrew FT-1 Tip from FN-1 Needle, gently pull back through ball shaped support and remove Tip.
3. Clean Parts carefully, using nothing harder than a wooden toothpick.
4. To reassemble, reverse this procedure, making sure the shoulder of the needle seats up against ball shaped support.
5. If the needle and tip are completely clogged, soak in a closed bottle of proper solvent until clean.

Paasche Airbrush Company

4311 North Normandy Avenue

Chicago, IL 60634-1395

Phone: 773-867-9191 • Fax: 773-867-9198

Website: paascheairbrush.com

E-Mail: info@paascheairbrush.com

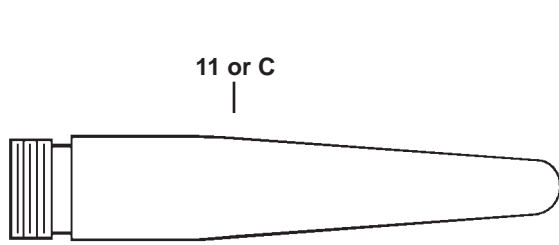
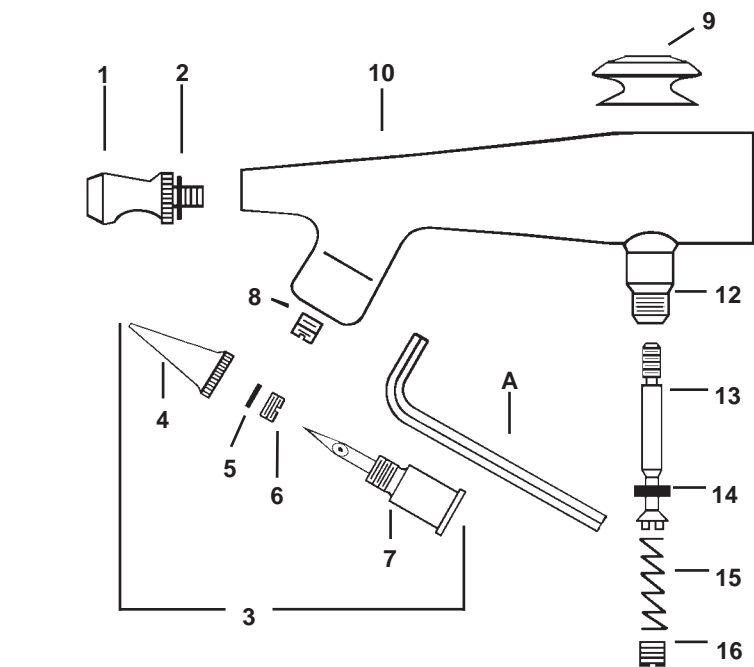

Item	Part No.	Description
1.	HC-1	Aircap
2.	3A-4	"O" Ring
3.	F-1	Color Adjusting Part
4.	FT-1	Tip (Nickel Silver)
5.	F-185	Packing
6.	F-184	Nut
7.	FN-1	Needle (Nickel Silver)
8.	H-153	Set Screw
9.	H-155	Finger Button
10.	F-190N	Shell
11.	F-143	Handle
12.	F-194	Valve Casing
13.	F-192	Air Valve Plunger
14.	A-52	Valve Washer (Dozen)
15.	A-22	Valve Spring
16.	A-23A	Air Valve Nut
A.	F-186	Wrench
B.	A-34	Hanger
	V-62	Wrench
C.	AFV-143	Metal Handle (Not Included)

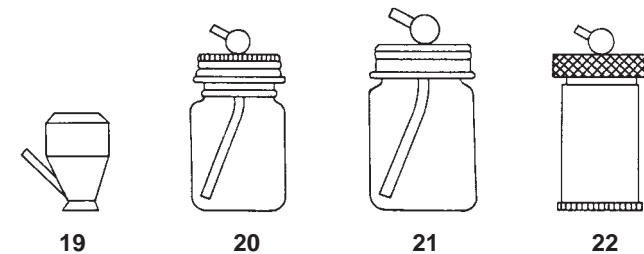
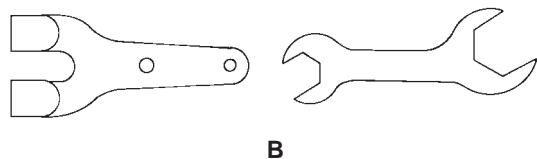

Metal Color Cups and Bottle Assemblies:

19.	F-1/4-OZ	1/4oz. Metal Color Cup (7cc)
20.	VFA-1/2-OZ	Glass Bottle Assembly (14.5cc)
	VFA1/2	1/2 oz. Cover Assembly Complete
	VF-7	Color Tube
21.	VFA-1-OZ	Glass Bottle Assembly (29cc)
	VFA1	1 oz. Cover Assembly
	5-G	Gasket
	VF-7	Color Tube
22.	V-1-OZ	Aluminum Cup Assembly (29cc)
	VF-26	1 oz. Aluminum Cup
	VF-7	Color Tube
	AE-31	Gasket

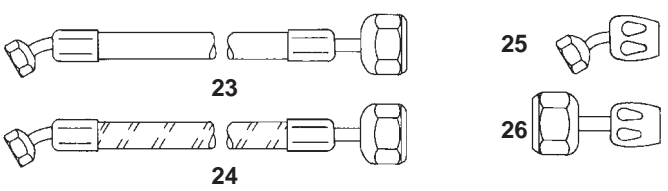

Air Hoses W/Factory Installed Couplings:

23.	A-1/8-8	Braided Airhose W/Couplings
24.	HP-1/8-8	PVC-Red Plastic Hose W/Cplgs.

Airhose Couplings-Replacement Only

25.	AC-20	1/8"-1/4"-40 Coupling (Airbrush)
26.	AC-1/8	-1/4" Coupling (Compressor)

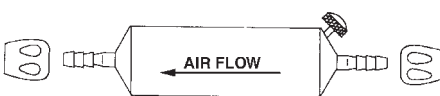
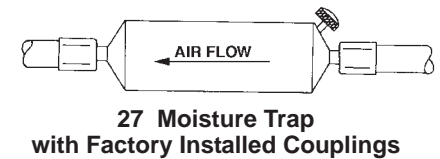

Accessories- NOT INCLUDED

27.	MT	Moisture Trap
28.	HF-1/4	Valve Assembly