

FP-1/32 Flow Pencil

OPERATING INSTRUCTIONS & REPLACEMENT PARTS

WARNING: Striping materials may be harmful if inhaled or allowed to come into contact with the skin or eyes. Consult the product label and Material Safety Data Sheet supplied for the spray material. Follow all safety precautions.
CAUTION: Well Ventilated Area Required to remove fumes.



Comes with LN-1/32 (Assembled) and LN-1/64, 3/64, and 1/16 Nibs loose
Total Length of Flow Pencil is 5 -1/2 inches.
HAPK Kit comes with one size nib only

INTRODUCTION:

The **FP-1/32 Flow Pencil** is used extensively by Designers, Sculptors, Hobbyists, Crafters, Ceramicists, Artists, Bakers, Furniture Manufacturers, and others to beautify their products. The Flow Pencil is easy to control and operate.

MIXING COLORS:

1. Proper mixing of colors is essential for continuous and uninterrupted striping.
2. Mix colors into a free flowing consistency, strain to remove any lumps.
3. Do not mix color in cup of Flow Pencil, use a separate container and pour into cup only when color flows freely.
4. Increase color to heavier consistency for wider stripes.

COLOR ADJUSTMENTS:

1. Remove **MU-20 Cover**, and pour premixed free flowing color into cup, then replace cover.
2. If necessary, blow thru the vent hole located in the center of the **MU-20 Cover** to start flow of heavier materials the first time, after which color should feed freely by gravity. If it does not flow it is too heavy.
3. Turning the **N-20 Adjusting Screw** will control the stroke of the **MU-65 Finger Lever Assembly** which controls the flow of color.

OPERATION:

1. Hold the **FP-1/32 Flow Pencil** in your hand as you would a pencil or brush and place your finger lightly over the **MU-65 Finger Lever**. When ready to stripe, pull back on the **MU-65 Finger Lever**. The Flow Pencil should be moved in a backward motion (away from the paint) after the color has begun to flow, never push it into the paint.

2. Regulate the flow to the desired feed rate by turning **N-20 Adjusting Screw**.
3. Keep vent hole in the **MU-20 Cover** open.
4. Practice striping before working on finished product.
5. Correct adjustment of controls and skill of operation will result in uninterrupted and continuous striping.

CARE AND CLEANING:

1. Before storing **FP-1/32 Flow Pencil** clean it thoroughly. Empty remaining color from the cup and rinse it with solvent. Pull back on the **MU-65 Finger Lever** and allow solvent to flow through cup, shell and nib.
2. If color has hardened in hole of nib use a tooth pick or needle dipped in solvent to remove accumulation.
3. **MU-49 Needle** is held in position by **MU-57 Needle Chuck** and **VL-141 Locknut**. Remove the needle by unscrewing the **MU-64 Handle** and removing the spring. Loosen the **VL-141 Locknut** and then remove the needle for cleaning.

ADJUSTING OR REPLACING WORN PACKING WASHER:

1. If Teflon® Packing-#6 becomes worn or loose it must be tightened or replaced.
2. You will need a small screwdriver to remove or tighten the Packing Nut.
3. When replacing your Teflon® Packing press Packing onto the Packing Nut-#6. Use a small screwdriver to tighten packing nut into shell until it is tight then back out one-half turn, may vary.
4. Now insert needle - you should feel a slight resistance. If too loose or too tight adjust the Packing Nut with screwdriver until you feel some slight resistance.
5. Now completely re-assemble guts of Flow Pencil.

PRESSURE CUP APPLICATION (CUP NOT INCLUDED)

The **ALP-32 Pressure Cup** can be used for heavy consistency colors for embossed or raised lines. A power plunger pressurizes the liquid for color feed that is more consistent with heavier materials.

Paasche Airbrush Company

4311 North Normandy Avenue
Chicago, IL 60634-1395

Phone: 773-867-9191 • Fax: 773-867-9198

Website: paascheairbrush.com

E-Mail: info@paascheairbrush.com

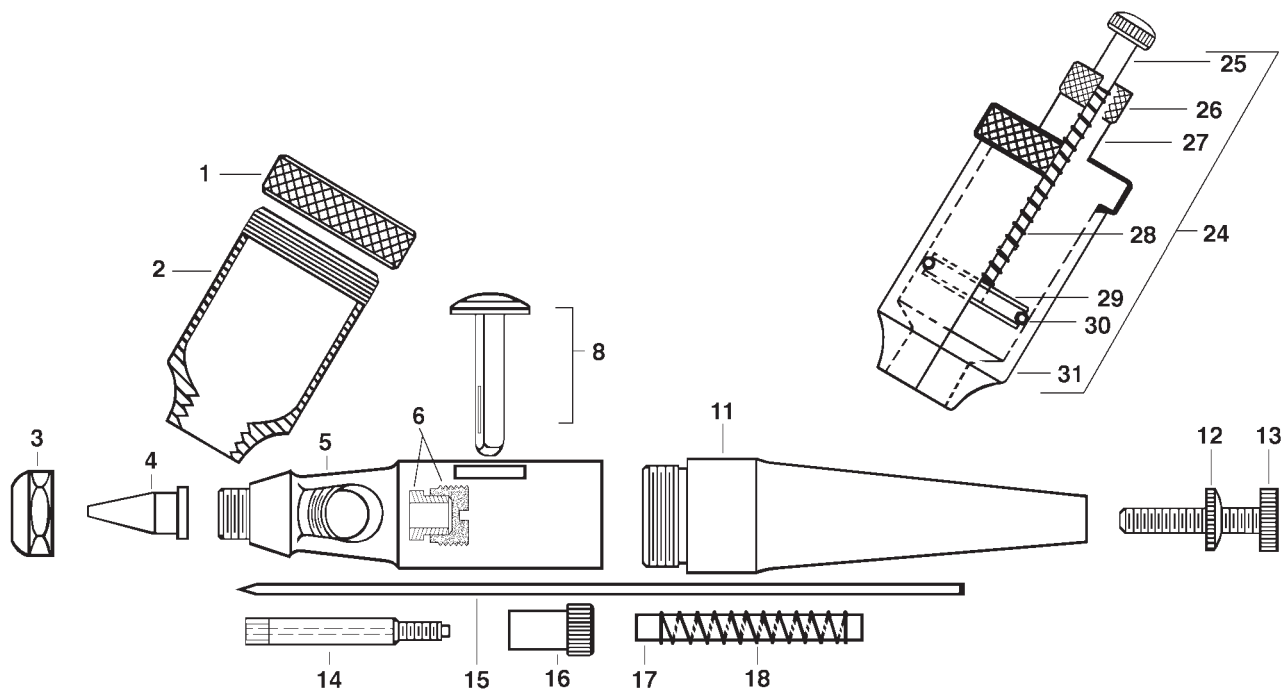

FP-1/32 FLOW PENCIL (WITH EXTRA NIBS: LN-1/64, 3/64 AND 1/16)

HAPK KIT comes with one size nib only

Nibs are grooved as follows:

LN-1/64 has one (1) groove

LN-1/32 has two (2) grooves

LN-3/64 has three (3) grooves

LN-1/16 has four (4) grooves

<u>No.</u>	<u>Part No.</u>	<u>Description</u>	<u>No.</u>	<u>Part No.</u>	<u>Description</u>
1	MU-20	Cover (only)	16	VL-141	Locknut
2	MU-21	Cup (only) Aluminum	17	MU-60	Needle Stop Tube
3	MU-9	Tip Nut	18	VL-140	Spring
4	LN-1/32	Nib (1/64, 3/64 & 1/16 Sizes)	<u>Optional Accessories</u>		
5	MU-48	Shell Assembly	24	ALP-32	Pressure Cup
6	MU-612	Teflon® Packing & Packing Nut (sold as set) ® DuPont	25	MU-25	Rod & Cap Assembly
8	MU-65	Finger Lever Assembly	26	MU-69	Nut
11	MU-64	Handle	27	MU-67	Cover (only)
12	N-21	Locknut	28	MU-26	Spring
13	N-20	Adjusting Screw	29	MU-70	Piston
14	MU-57	Needle Chuck	30	MT-21	"O" Ring
15	MU-49	Needle	31	MU-21	Cup (only) Aluminum